

## Trouble shooting

SYMPTOMS	CHECK	REMEDY
<b>NO SOUND</b>	Is the power LED illuminated? (NO)	Check all fuses to amplifier. Be sure turn-on lead is connected Check signal leads. Check gain control. Check Tuner/Deck volume level. Clean contacts on fuse holders.
	Is the Diagnostic LED illuminated?(YES)	Check for speaker short or amplifier overheating.
<b>AMP NOT SWITCHING ON</b>	No power to power wire	Repair power wire or connections.
	No power to remote wire with receiver on	Check connections to radio.
	Burnt or broken fuse	Replace fuse.
<b>NO SOUND, ON ONE CHANNEL</b>	Check Speaker Leads	Inspect for short circuit or an open connection.
	Check Audio Leads	Reverse Left and Right RCA inputs to determine if the problem is occurring before the amp.
<b>AMP TURNING OFF MEDIUM/HIGH VOLUME</b>	Check Speaker load impedance	Be sure proper speaker load impedance recommendations are observed.  (If you use an ohmmeter to check speaker resistance, please remember that DC resistance and AC impedance may not be the same.)
<b>PROTECTION LAMP ON</b>	Shut down	Turn radio down Wait for AMP to cool
	Speaker wires shorted	Separate speaker wires and insulate

## Warning

Investigate the layout of your vehicle before drilling or cutting any holes. Take care when you are working near the gas tank, brake lines, hydraulic lines, and electrical wiring. Do not use the amplifier without security mounting it, as the amp or vehicle may be damaged in the event of an accident. Do not mount the amplifier where the wire connections are unprotected or are subject to pinching or damage from other vehicle components. The 12V power wire must be fused within 18" of the battery. Ensure the source unit is powered off before making any wiring connections. If you need to replace the fuses, use only the same type and size. Using a fuse of a different type or rating may result in damage to the amplifier or vehicle, which will not be covered under the manufacturer's warranty.



## OWNER'S MANUAL

— **CAR AUDIO SYSTEM** —  
**PLEASE READ CAREFULLY BEFORE INSTALLING  
OR OPERATED THIS UNIT**  
HIGH EFFICIENCY POWER AMPLIFIER



## WARNING

Make sure you choose a suitable place to mount the unit. The position should be completely dry with a good circulation of air, and from a mechanical point of view very stable.

## Features

- Class-D digital full range 2ohm stable stereo.
- Applying new concept "low-Heat Producing Circuit".
- Tri-mode capable.
- Channel design 4/ 3 /2 channels.
- Full MOSFET DC-DC PWM power supply.
- Four way protection.
- Double sided FR-4 PC Board.
- SMD technology.
- Ni plated RCA input connectors.
- Adjustable Low-Pass, Hi-pass.
- Connector terminals: NI 4Guage input block type power terminal and 4Guage out speak block type terminals.
- Ultra slim size.

## Power Connections

It is important to have good quality power and ground connections. Remember, to complete an electrical circuit, the ground connection is just as important as the positive power connection. Before any power connections are made, disconnect the ground cable of the battery . Use 8 gauge or larger automotive grade wire if the distance from the battery to the amp is excessive. Avoid sharp or rough edges as a safeguard against short circuiting and potential fire hazards.

**GND=** Connect the proper gauge ground wire to the amplifier GND terminal. Locate the position on the chassis of the car where the amplifier will be grounded. Use solder or a crimped ring terminal to connect the ground wire pre-drill the prepped chassis to bolt the ground ring terminal with a nut, bolt, and lock washer Insulate the metal and the connector with paint or silicone to prevent rust and oxidation. Silicone also works great to prevent nuts and bolts from working loose in harsh environments of an automobile. Upon completion of the ground connection, grab the wire and connector to confirm the connection is solid. To prevent engine noise, it is recommended to ground the head unit and other electronic audio devices to the same location.

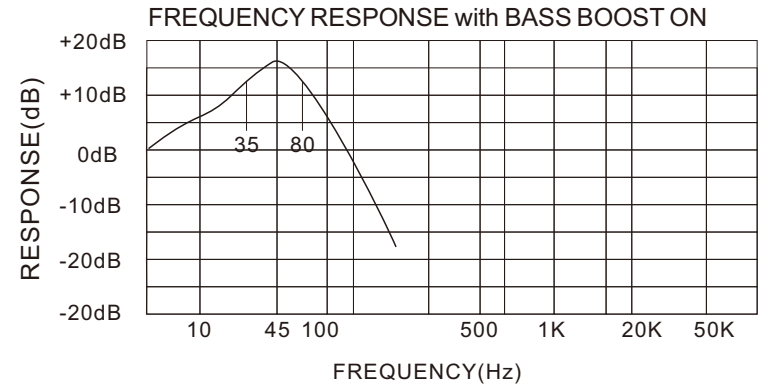

## Mounting Your Amplifier

Choosing the best mounting location for your amplifier is crucial. The amplifier should be mounted to any wood, metal, or carpeted surface. The heatsink can be mounted directly to the chassis of the car, or isolated for best performance. It needs proper ventilation, so avoid mounting the amp under seats, in the engine bay, or any other area that moisture might accumulate. Be sure the mounting screws do not penetrate the fuel tank, brake lines, or any other crucial fluid lines. Never mount the amplifier to a subwoofer enclosure, as excessive vibrations can cause damage

### Warning

We highly recommends that an in-line fuse or circuit breaker be installed within 18" of the battery. Although your amplifier has adequate internal protection, it is possible a damaged wire between the component and the battery may result in a fire. The in-line fuse or circuit breaker should be installed in a location that is easy to access, and all wiring should be routed safely, following the below suggestions:

- Avoid placing wires near hot or moving objects
- Always use wire grommets when routing wire through the firewall or any other metal surfaces
- Avoid the potential for damaged wires by routing all wires away from moving hinges, seats, brake & gas pedals, hood and trunk hinges, etc.

## Setting the gains

It is a fact that very few people, including professional installers, know how to set gains correctly. Failure to do so yields higher distortion, a higher noise floor which decreases dynamic headroom, less than optimum operating conditions for electronic equipment, and higher failure rate for both the electronic equipment and transducers alike.

While most people set this control by ear to how loud they want their music, this is not the intent of this control. The range is from 0.25 volts to 6 volts. The control is meant for matching the output of the source unit's signal voltage. For example, if you have a source unit with low output voltage, you would probably have the control set fairly high, towards the 0.25V range. A lot of head units have 4 volts of output signal voltage which means that your control would be set midway through the range. If you happen to have a line driver (signal booster) that yields 6 volts or more, you will set the gain at the minimum position, towards the 6V range.

In all of these examples, when properly level matched, the amplifier will put out full volume. Setting the control above the proper point may cause damage to the amplifier and speakers and can result in poor sound quality and overall undesirable results.

## Bass boost control

The monoblock amplifiers feature a variable bass boost control centered at 45Hz. You can adjust the amount of boost from 0dB to 18dB.

**REM=** Connect the remote wire (power antenna output) from the head unit to the REM terminal. If the head unit is not equipped with a remote/antenna output, locate a wire that is controlled by the accessory position of the key. It is important to have the amplifier turn off with the radio or key. If the amplifier remains on, the battery will drain.

**12V=** Connect the proper gauge power wire to the B+ terminal. Trace the power wire through the car to the in-line fuse or circuit breaker that is no more than 18" from the battery. Remember, the in-line fuse or circuit breaker protects the car in the event of short circuit, Connect the in-line fuse or circuit breaker to the battery, but do not install the fuse or activate the circuit breaker yet.

power connection.

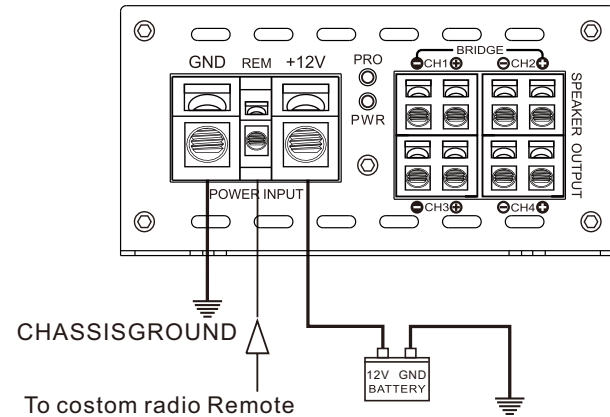

## Speaker Out Connections

### STEREO MODE

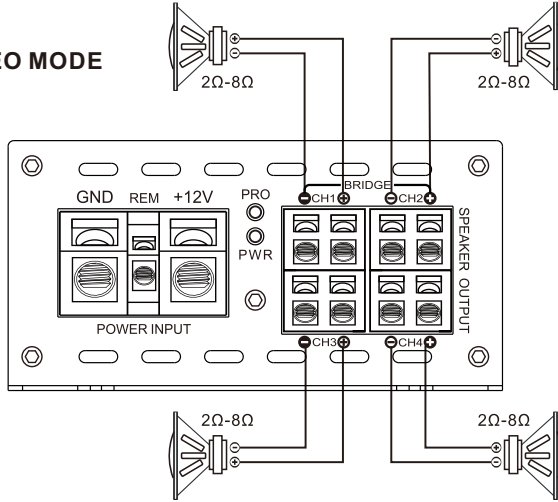

### BRIDGED MODE

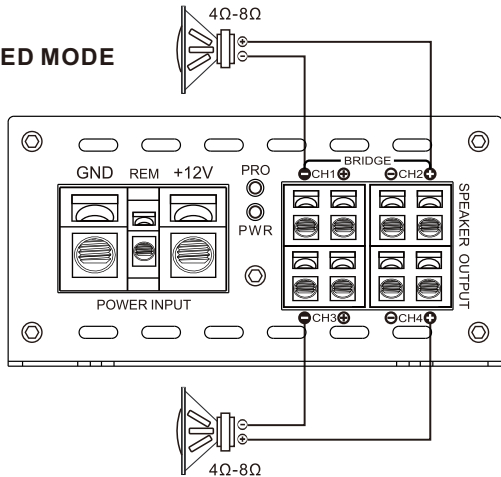

## FEATURES

### 1. Power Protection Indicator LED

When the amplifier is on and in proper working condition, the green LED will illuminate. Refer to the Troubleshooting Guide for possible solutions if the amplifier will not power on. If the amplifier activates its protection mode, the red led will illuminate. Refer to the Troubleshooting Guide for possible solutions if the amplifier activates its protection mode.

### 2. Level Sensitivity

Adjust the amplifiers pre-amp sensitivity level. The minimum sensitivity level is 250mv, while the maximum level is 6V.

**Note:** Remote trigger input power must be connected well tight and firmly on the 3.5 pie port, Amplifier won't be able to turn on if its loosen or not connected.

### 3. RCA Audio Input Connection

Using high quality shielded stereo RCA cables, connect the source signal to the amplifier RCA inputs.

### 4. Crossover Selection Switch

Choose an 80Hz fixed frequency high pass crossover, 80Hz fixed frequency low pass crossover, or full range operation.

